

AI Survey - Laser Conversion Chart

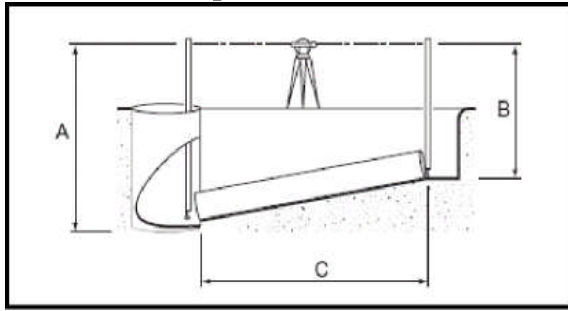

$$\% \text{ of Grade} = \left[\frac{(A-B)}{C} \right] \times 100$$

1 in 10 = 10.000%	1 in 48 = 2.083%	1 in 86 = 1.163%	1 in 220 = 0.455%	1 in 410 = 0.244%
1 in 11 = 9.091%	1 in 49 = 2.041%	1 in 87 = 1.149%	1 in 225 = 0.444%	1 in 415 = 0.241%
1 in 12 = 8.333%	1 in 50 = 2.000%	1 in 88 = 1.136%	1 in 230 = 0.435%	1 in 420 = 0.238%
1 in 13 = 7.692%	1 in 51 = 1.961%	1 in 89 = 1.124%	1 in 235 = 0.426%	1 in 425 = 0.235%
1 in 14 = 7.143%	1 in 52 = 1.923%	1 in 90 = 1.111%	1 in 240 = 0.417%	1 in 430 = 0.233%
1 in 15 = 6.667%	1 in 53 = 1.887%	1 in 91 = 1.099%	1 in 245 = 0.408%	1 in 435 = 0.230%
1 in 16 = 6.250%	1 in 54 = 1.852%	1 in 92 = 1.087%	1 in 250 = 0.400%	1 in 440 = 0.227%
1 in 17 = 5.882%	1 in 55 = 1.818%	1 in 93 = 1.075%	1 in 255 = 0.392%	1 in 445 = 0.225%
1 in 18 = 5.556%	1 in 56 = 1.786%	1 in 94 = 1.064%	1 in 260 = 0.385%	1 in 450 = 0.222%
1 in 19 = 5.263%	1 in 57 = 1.754%	1 in 95 = 1.053%	1 in 265 = 0.377%	1 in 455 = 0.220%
1 in 20 = 5.000%	1 in 58 = 1.724%	1 in 96 = 1.042%	1 in 270 = 0.370%	1 in 460 = 0.217%
1 in 21 = 4.762%	1 in 59 = 1.695%	1 in 97 = 1.031%	1 in 275 = 0.364%	1 in 465 = 0.215%
1 in 22 = 4.545%	1 in 60 = 1.667%	1 in 98 = 1.020%	1 in 280 = 0.357%	1 in 470 = 0.213%
1 in 23 = 4.348%	1 in 61 = 1.639%	1 in 99 = 1.010%	1 in 285 = 0.351%	1 in 475 = 0.211%
1 in 24 = 4.167%	1 in 62 = 1.613%	1 in 100 = 1.000%	1 in 290 = 0.345%	1 in 480 = 0.208%
1 in 25 = 4.000%	1 in 63 = 1.587%	1 in 105 = 0.952%	1 in 295 = 0.339%	1 in 485 = 0.206%
1 in 26 = 3.846%	1 in 64 = 1.563%	1 in 110 = 0.909%	1 in 300 = 0.333%	1 in 490 = 0.204%
1 in 27 = 3.704%	1 in 65 = 1.538%	1 in 115 = 0.870%	1 in 305 = 0.328%	1 in 495 = 0.202%
1 in 28 = 3.571%	1 in 66 = 1.515%	1 in 120 = 0.833%	1 in 310 = 0.323%	1 in 500 = 0.200%
1 in 29 = 3.448%	1 in 67 = 1.493%	1 in 125 = 0.800%	1 in 315 = 0.317%	1 in 525 = 0.190%
1 in 30 = 3.333%	1 in 68 = 1.471%	1 in 130 = 0.769%	1 in 320 = 0.313%	1 in 550 = 0.182%
1 in 31 = 3.226%	1 in 69 = 1.449%	1 in 135 = 0.741%	1 in 325 = 0.308%	1 in 575 = 0.174%
1 in 32 = 3.125%	1 in 70 = 1.429%	1 in 140 = 0.714%	1 in 330 = 0.303%	1 in 600 = 0.167%
1 in 33 = 3.030%	1 in 71 = 1.408%	1 in 145 = 0.690%	1 in 335 = 0.299%	1 in 625 = 0.160%
1 in 34 = 2.941%	1 in 72 = 1.389%	1 in 150 = 0.667%	1 in 340 = 0.294%	1 in 650 = 0.154%
1 in 35 = 2.857%	1 in 73 = 1.370%	1 in 155 = 0.645%	1 in 345 = 0.290%	1 in 675 = 0.148%
1 in 36 = 2.778%	1 in 74 = 1.351%	1 in 160 = 0.625%	1 in 350 = 0.286%	1 in 700 = 0.143%
1 in 37 = 2.703%	1 in 75 = 1.333%	1 in 165 = 0.606%	1 in 355 = 0.282%	1 in 725 = 0.138%
1 in 38 = 2.632%	1 in 76 = 1.316%	1 in 170 = 0.588%	1 in 360 = 0.278%	1 in 750 = 0.133%
1 in 39 = 2.564%	1 in 77 = 1.299%	1 in 175 = 0.571%	1 in 365 = 0.274%	1 in 775 = 0.129%
1 in 40 = 2.500%	1 in 78 = 1.282%	1 in 180 = 0.556%	1 in 370 = 0.270%	1 in 800 = 0.125%
1 in 41 = 2.439%	1 in 79 = 1.266%	1 in 185 = 0.541%	1 in 375 = 0.267%	1 in 825 = 0.121%
1 in 42 = 2.381%	1 in 80 = 1.250%	1 in 190 = 0.526%	1 in 380 = 0.263%	1 in 850 = 0.118%
1 in 43 = 2.326%	1 in 81 = 1.235%	1 in 195 = 0.513%	1 in 385 = 0.260%	1 in 875 = 0.114%
1 in 44 = 2.273%	1 in 82 = 1.220%	1 in 200 = 0.500%	1 in 390 = 0.256%	1 in 900 = 0.111%
1 in 45 = 2.222%	1 in 83 = 1.205%	1 in 205 = 0.488%	1 in 395 = 0.253%	1 in 925 = 0.108%
1 in 46 = 2.174%	1 in 84 = 1.190%	1 in 210 = 0.476%	1 in 400 = 0.250%	1 in 950 = 0.105%
1 in 47 = 2.128%	1 in 85 = 1.176%	1 in 215 = 0.465%	1 in 405 = 0.247%	1 in 975 = 0.103%
				1 in 1000 = 0.100%

Web: www.proshotlaser.co.uk E-mail: info@proshotlaser.co.uk

Phone: 0845 500 5858

Fax: 08701 322350

